

## User Guide for 52mm Gauge

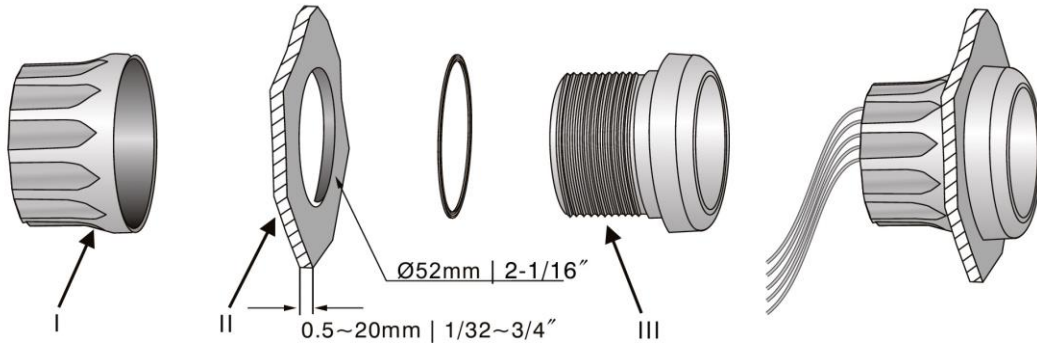

### 1) Wiring Guide for Oil Pressure Gauge

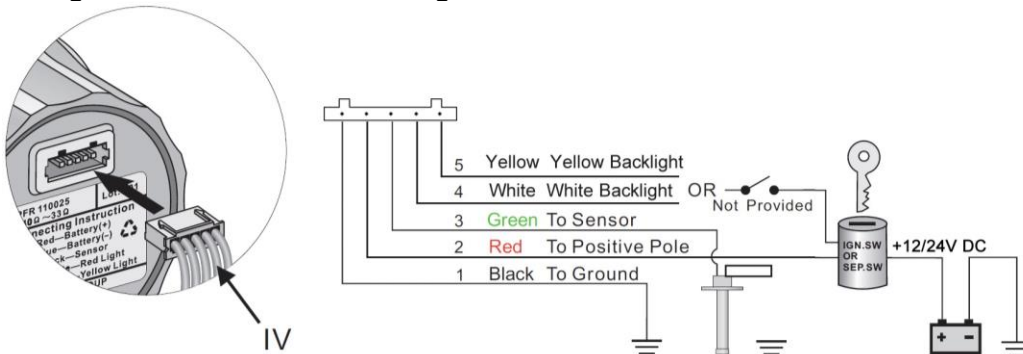

1. Cut a 52mm (2 1/16 ) diameter panel hole (II).  
You will need a minimum clearance of 55mm (2 3/16 ) behind the panel to fit the gauge.
2. Remove fastening ring (I).  
There is an alignment tab on the gauge body (III), place the gauge in the panel hole and mark the position of this tab to correctly align the gauge.
3. Insert gauge through panel from the front, fit and tighten fastening ring (I) from the rear.
4. Connect wires according to wiring instruction. Select either White or Yellow wires for backlighting. Wire colour corresponds with backlighting colour.
5. Insert wire harness (IV) into port at the back of the gauge