

User Manual for 85mm Tachometer + Hour Meter

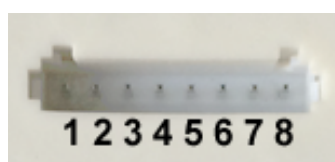
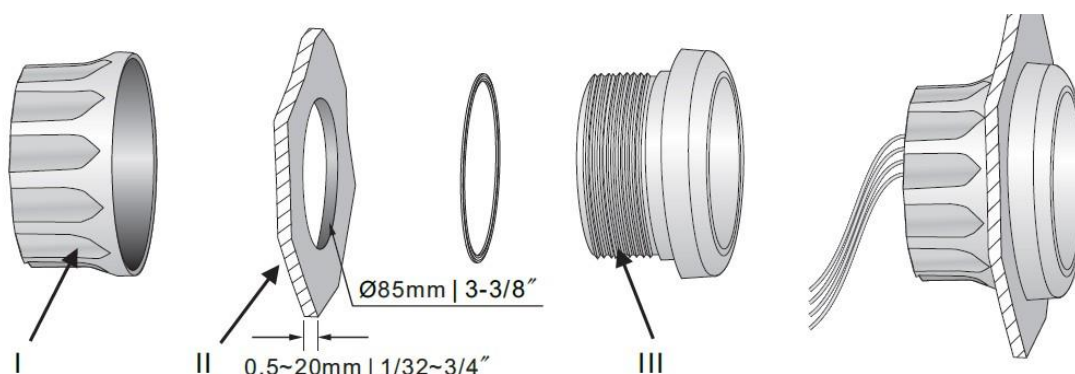

- 1.GND 2.ING+(8~80V DC) 3. RPM Signal or W-Terminal
4.Voltage Output(8V+) 5. Yellow Backlight (+) 6. Red Backlight(+)
7.External Button (+) 8.Connect DC +12V for Emergency Status Only

1. Cut an 85mm (3 3/8") hole in the panel (II) allow a clearance of . behind the panel.
2. Remove fastening ring (I),insert gauge from front. Tighten gauge (III) using fastening ring (I)
3. Connect cables according to the diagram.

a. Only connect PIN 1,2,3,4,5 in normal installation and use.

Please do NOT connect pin 8.

b. Emergency Connect:

If Tachometer is Burnt/Faulty, then the LCD will be blind. Please connect PIN1 & PIN8 to read the latest value of LCD Hour Meter.

Function Select: "PULSE" , "HOUR" , "BUZZ"

Press and hold on the back button or external button, then turn on the power supply.

The LCD will show PULSE, HOUR, BUZZ, etc.

You can select the function to be set after release button.

1. "PULSE" (change RPM Ratio)

After selecting "PULSE", the LCD will show for example "P 3" (3 means 3pulses per round) after 3 seconds. Press the button to change the flashing digit in the LCD

User Manual for 85mm Tachometer + Hour Meter

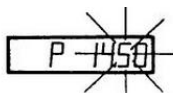

You can select "PULSE" again to confirm the setting is done.

How to confirm RPM Ratio?

- If your sensor is installed on the flying wheel panel, the RPM ratio is equal to the number of gears of the engine.
- If the speed signal takes from **W-Terminal**, the RPM ratio is equal to the half of the number of poles.

Normal RPM Ratio for Reference:

OutBoard Engine		InterBoard or Gasoline Engine			Diesel Engine
Electric Poles	RPM Ratio	Cylinder	Stroke	RPM Ratio	RPM Ratio=Gear Number
4	2	4	4	2	
6	3	6	4	3	
8	4	8	4	4	
10	5	10	4	5	
12	6	12	4	6	

2. "HOUR" (change total hour meter)

After selecting "HOUR", the LCD will show for example "5000" (5000 HOUR), press the button to change the flashing digit from 0 to 99999 to set the target odometer value.

3. "BUZZ" (change overspeed buzzer alarm threshold value)

After selecting "BUZZ", the LCD will show for example "B 3000" (buzzer will be on when speed over 3000RPM), press the button to change the flashing digit from 0 to 8000 to set target overs RPM buzzer alarm threshold value.

Please noted: After setting, you should disconnect both Power+ and GND, and then reconnect the two cable, then it will save the setting. If you just cut Power +, then it'll not work properly.